

**ECM**



DISTRIBUTED BY:

**Sedulitas**

PEOPLE | PASSION | PRECISION

info@sedulitas.co.za +27 (0)82 551 4001  
www.sedulitas.co.za

## *Electric contact pressure controllers*

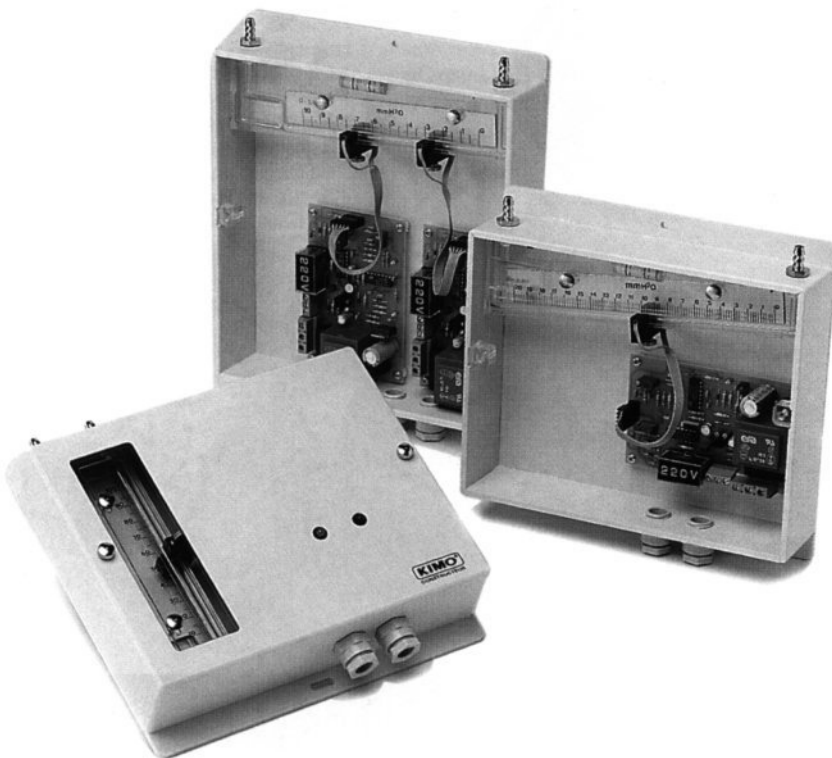

KIMO has designed and manufactured the ECM electric contact pressure controller to combine the inherent reliability and accuracy of the liquid column manometer with electronic switching.

The operating principle gives unrivalled performance when compared to traditional pressure controllers.

The KIMO ECM electric contact pressure controllers excel where it is necessary to monitor small variations in low pressures of air or gas and where accurate and reliable monitoring is essential.

The ECM is widely used in pharmaceutical laboratories, clean rooms and other areas where good performance is essential.

- Positive, negative and differential pressure measurement, with the option of 1, 2 or multiple electric contacts on the same scale.
- Electric contacts from 0,5 mm H<sub>2</sub>O (5 Pa).
- Delay adjustable from 0 to 45 seconds.
- Contact rating : 3A at 230 V. - 50 Hz.
- Operation of the contact on rising or falling pressure, by using the inverter function.
- Simple pressure setting by cursor on graduated scale.
- Max. static pressure of 6 bar, when used on differential pressure.
- Pressure and switching points continuously displayed.
- Switch position indicated by LED.

## Features available

Réf.	Scale in mm H2O	Scale length for 1 mm H2O	Liquid Ref. and density	Standard version	Minimum setting	Min. separation between 2 contacts
Inclined						
<b>ECM 88</b>	8-0-8	8 mm	AWS10 D = 0,87	1 or 2 contacts	< 0,10 mm CE	< 0,5 mm CE
<b>ECM 20</b>	0-20	8 mm	"	"	< 0,10 mm CE	< 0,5 mm CE
<b>ECM 60</b>	0-60	3 mm	"	"	< 0,50 mm CE	< 1,5 mm CE
Vertical						
<b>ECM 150</b>	0-150	1 mm	"	1 or 2 contacts	< 1 mm CE	< 4 mm CE
<b>ECM 300</b>	0-300	0,5 mm	"	1 or 2 contacts	< 2 mm CE	< 8 mm CE

Delivered empty in cardboard packing with appropriate manometer liquid, 2 screws, fixing bolts and operations for use.

## Specification

- Operation : pressure (+), vacuum(-), differential pressure ( $\Delta P$ ).
- Scale : vertical or inclined.
- Manometer : transparent altuglass M.70, thickness 15 mm.
- Liquid column drilled  $\varnothing$  4 mm.
- Scale : transparent altuglas M.70, section 20 x 2 mm.
- Graduation : black printing.
- Zero Ajustment by moving the graduated scale, up to 10 mm, clamping by nickeled brass thumb screw.
- Integral spirit level for horizontal setting.
- Manometric liquid : AWS.10, density 0,87 red or Volt 1S, density 1,86 blue depending on the model.
- Connection : clear tube  $\varnothing$  5 x 8 mm on nickeled brass serrated connections or direct on the instrument, threading 1/8 gas.
- Maximal static pressure : 6 bars.
- Reading accuracy :  $\pm 1$  % of the inclined scale ;  $\pm 0,5$  % of the vertical scale.

### ● UF 313-1 AMPLIFIER :

- Power supply: 230 Vac, 110 Vac, 24 Vdc or 24 Vac.
- Relay outputs : inverter electrical contact R.T. 3A/230V  $\sim$  50 Hz.
- Consumption : 50 mA.
- Indicating light : red LED which indicates the relay contact position. Switch-on = Lit
- Micro-switch : Inverter switch for inverter function (see operating).
- Delay : potentiometer (one rotation), setting from 0 to 45 seconds.
- Sensitivity : potentiometer (one rotation) permits adjustment of photo electric sensor for different manometer liquids.
- Limit operating temperature : - 5 to + 50°C.
- Electrical connection : screw terminals and gland CM6P, cover PE7.
- Dimension : 110 x 70 mm. Weight : 140 g.

### ● PHOTO-ELECTRICAL CURSOR :

- Optical signaling mechanism : photo-electric transmitter-receiver connected to : the amplifier by optical fiber.
- Transmitter : infra-red light.
- Not sensitive to other light sources.
- Size : altuglas dim. 30 x 15, length 10 mm.
- Setting : by location on the graduated scale.  
Knurled locking screw in nickled brass.
- Red mark on the altuglass cursor, for adjustment of the switching point or of reset point.

### ● HOUSING :

- PS shock, ral. 9002, colour : sand..
- Cover : cover front retained by two nickled brass knurled screws.
- Viewing window : transparent altuglas M.70.
- Fixing : wall mounting by 2 screws.  $\varnothing$  4 or 5 mm.

## Operation

The ECM can be fitted to a vertical or inclined manometer. The photo electric sensor is connected to a PCB by an optical fibre. When energised the PCB generates an infra-red ray which travels along the optic fibre and through the manometer liquid column. The PCB senses when the liquid column breaks the infra-red ray and operates the switch either making or breaking the contact depending on how it is set.

The ECM can operate on rising or falling pressure by changing the position of the "inverter switch" on the PCB.

Diagrams 1 and 2 show the operation principle. The switch operates when the pressure rises and the manometer liquid breaks the infra-red ray at 100 mm H<sub>2</sub>O also lighting the LED.

When the inverter microswitch is operated (diagram 2) the switch operates when the pressure falls and the infra-red ray is re-established at 100 mm H<sub>2</sub>O.

The changeover relay enables the power to be switched on or off with a delay of up to 45 seconds. Multiple units can be fitted to one manometer column to perform different functions.

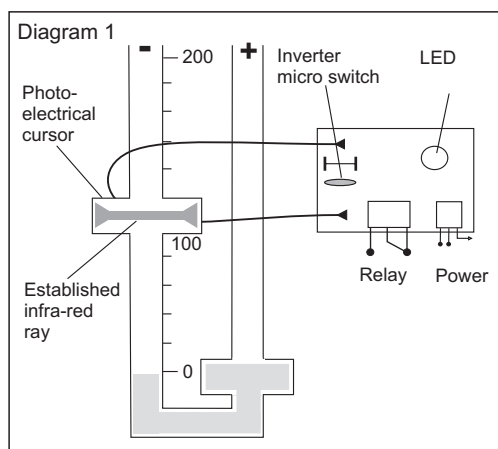

- Manometer to zero.
- Powered PCB.
- "Inverter" micro-switch .
- Established infra-red ray.
- LED - off.
- Broken "relay contact"

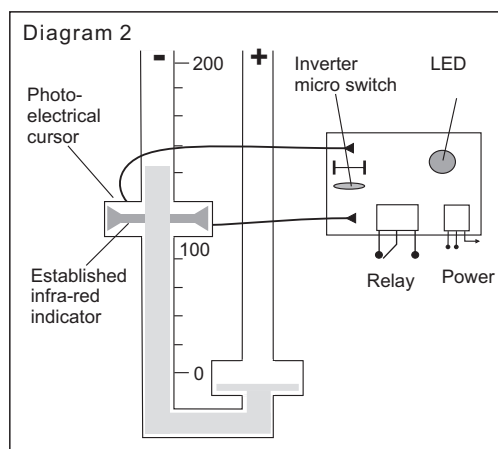

- Manometer pressurised.
- Infra-red ray cut off.
- LED - on.
- Made "relay contacts"

## Connection

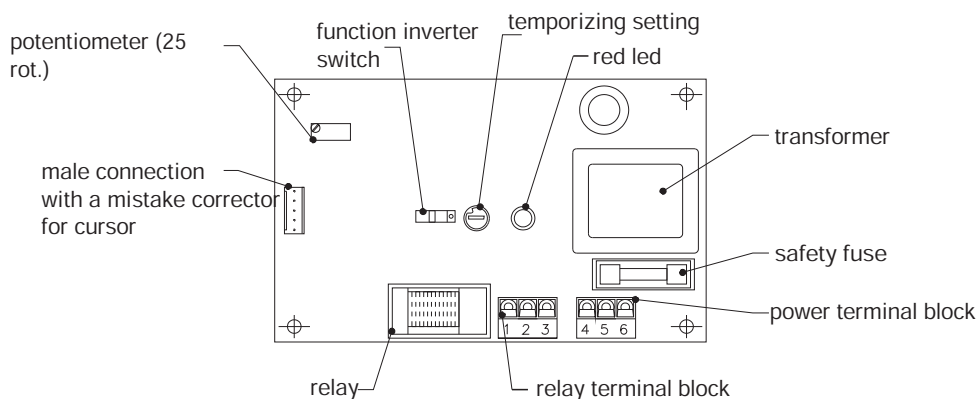

In 24 Vdc	In 24 Vac	In 230 Vac / 115 Vac
4 : +	4 : Connection	4 : phase
5 : -	5 : Connection	5 : neutral
6 : NC	6 : NC	6 : earth

- 1- NC
- 2- Common :220 V/3A
- 3- NO
- 4- Card power.
- 5- Card power.
- 6- Earth.

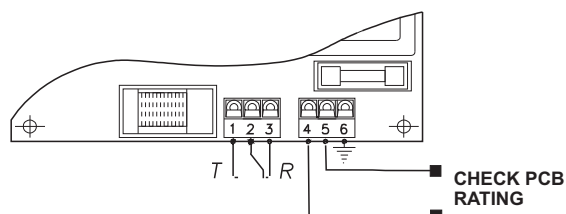

## Dimensions

Réf.	Version 1 contact - V1			Version 2 contacts - V2		
	Dimension in mm : H x W x T	Weight en g.	Fixing center EF in mm	Dimension in mm : H x W x T	Weight in g.	Fixing center EF in mm
Inclined						
<b>ECM 88</b>	248 x 204 x 75	1080	233	248 x 204 x 75	1080	233
<b>ECM 20</b>	248 x 204 x 75	1080	233	248 x 204 x 75	1080	233
<b>ECM 60</b>	248 x 204 x 75	1005	233	248 x 204 x 75	1150	233
Vertical						
<b>ECM 150</b>	248 x 204 x 75	1015	233	248 x 204 X 75	1165	233
<b>ECM 300</b>	248 x 204 x 75	1030	233	248 x 204 x 75	1180	233

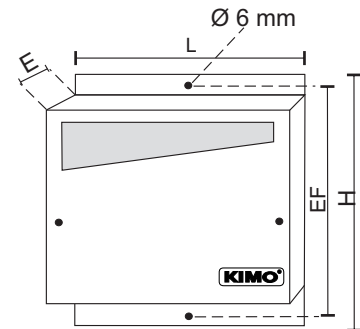

## Accessories

- ECM electronic card : Power supply 24, 48, 110 or 230 V.
- Detection cursor for ECM.
- Connections with security valve type 509.
- Buzzer ECM : 75 dB power-sound buzzer.

## Special applications

KIMO can make to order, all types of electric contact pressure controllers of the “photo-electric cursor with relay contacts” type with 3, 4, 5 contacts or more.

Different contacts, scales, and other densities possible.

Special designs for detecting high levels in vats.

ECM can be supplied without cover, and can be mounted on a support to be installed safety housings.

**We have the instrument you need.  
Consult us.**

## Service

The ECM do as not need any particular service. We simply recommend that the indicator liquid is changed every year, to ensure the photo electric cell work properly.

[www.kimo.fr](http://www.kimo.fr)



**EXPORT DEPARTMENT**

Tel : + 33. 1. 60. 06. 69. 25 - Fax : + 33. 1. 60. 06. 69. 29

e-mail : [export@kimo.fr](mailto:export@kimo.fr)



**DISTRIBUTED BY:**

**Sedulitas**

PEOPLE | PASSION | PRECISION

[info@sedulitas.co.za](mailto:info@sedulitas.co.za) +27 (0)82 551 4001  
[www.sedulitas.co.za](http://www.sedulitas.co.za)