

831-INT & 831-INT-ET

831 Docking Station

Manual



Larson Davis

*831-INT & 831-INT-ET
Docking Station*

Manual

Copyright

Copyright 2017 by PCB Piezotronics, Inc. This manual is copyrighted, with all rights reserved. The manual may not be copied in whole or in part for any use without prior written consent of PCB Piezotronics, Inc.

Disclaimer

The following paragraph does not apply in any state or country where such statements are not agreeable with local law:

Even though PCB Piezotronics, Inc. has reviewed its documentation, PCB Piezotronics, Inc. makes no warranty or representation, either expressed or implied, with respect to this instrument and documentation, its quality, performance, merchantability, or fitness for a particular purpose. This documentation is subject to change without notice, and should not be construed as a commitment or representation by PCB Piezotronics, Inc.

This publication may contain inaccuracies or typographical errors. PCB Piezotronics, Inc. will periodically update the material for inclusion in new editions. Changes and improvements to the information described in this manual may be made at any time.

Record of Serial Number and Purchase Date

831-INT(-ET) Serial Number: _____ **Purchase Date:** _____

831-INT-ET MAC Address: _____

Recycling

PCB Piezotronics, Inc. is an environmentally friendly organization and encourages our customers to be environmentally conscious. When this product reaches its end of life, please recycle the product through a local recycling center or return the product to:

PCB Piezotronics, Inc.

Attn: Recycling Coordinator

1681 West 820 North

Provo, Utah, USA 84601-1341

where it will be accepted for disposal



Warranty

For warranty information, refer to our *Terms and Conditions of Sale* on our website www.larsondavis.com/TermsConditions.aspx.

Chapter 1	Introduction	1-1
	Overview	1-1
	Features	1-2
	Standard Accessories	1-3
	Optional System Accessories	1-4
Chapter 2	Assembly and Configuration	2-1
	Electrical Connection Overview	2-1
	Battery Connection.....	2-5
	Router Battery Connection.....	2-7
	Assembly Diagram.....	2-9
	Internal Jumpers.....	2-10
	Battery Charger	2-11
	Battery Temperature Sensor.....	2-11
	Watchdog	2-12
	Embedded Computer Enable.....	2-13
	Fuses.....	2-13
	Placement of Model 831	2-15
	Mounting 831-INT in an EPS031 or EPS043	2-16
	Configuring Routers for 831-INT-ET	2-17
Chapter 3	Operation	3-1
	Status Indicators.....	3-1
	Mains Power/External 15V DC Power	3-1
	Battery Charger Status	3-2
	System On Status	3-2
	USB Status	3-3
	831-INT-ET Operation	3-3
	Proper Shutdown Method.....	3-4
	Connecting to Model 831 through 831-INT-ET using G4 LD Utility.....	3-4
	Connecting to Model 831 through 831-INT-ET using SLM Utility-G3	3-5
	Battery Charger Operation	3-6
	Solar Power Operation	3-8
	System SLA Battery Capacity and Run-time	3-8
Appendix A	Technical Specifications	A-1
	Physical Characteristics	A-1
	Environmental Specifications	A-1
	831-INT-ET Docking Station with Ethernet.....	A-3

USB HUB	A-3
Outdoor Microphone System.....	A-3
Battery Charger.....	A-5
Battery Connector.....	A-5
Logic I/O & Auxiliary Power Connector	A-6
Power Specification	A-8
Power Consumption for Model 831, 831-INT, 831-INT-ET and Accessories	A-8
Mains Power	A-9
PSA030 Power Adapter	A-9
Battery.....	A-10
Internal Charger	A-10
Other Electrical Characteristics	A-11

Appendix B Troubleshooting B-1

Introduction

This chapter summarizes the features and accessories of the 831-INT and 831-INT-ET.

Overview

The information presented for the 831-INT is applicable to both 831-INT and 831-INT-ET.

The Larson Davis 831-INT is a companion product to the Model 831 Sound Level Meter that adds functionality needed for outdoor noise monitors. The 831-INT-ET includes functionality to support Ethernet communication.

It also enhances the capabilities of the Model 831 to include interfaces for components of a permanent noise monitoring system. Figure 1-1 shows the 831-INT-ET.



FIGURE 1-1 831-INT-ET

Features

Outdoor Microphone Preamplifiers

- Provides power and control signals for the 426A12 and PRM2103 outdoor microphone preamplifiers.

Battery Management

- Backup battery management and charge control.
- Connection for up to two 12 V sealed lead-acid (SLA) batteries using removable screw terminal connectors.
- Integrated multi-stage charger for SLA batteries. Efficient Switch-Mode Power Supply circuitry used to reduce heat and improve reliability.
- Automatic low battery shutdown prevents battery damage.
- Automatic power up when battery is charged sufficiently by Mains power or solar-powered charger.

Power Management

- Mains power with automatic switch over to battery power when mains power fails.
- Support for solar power.
- LED Indicators:
 1. Mains Power On.
 2. Charger Status.
 3. System Power Status, including shutdown status and low battery status.
 4. USB Hub Power On.
- Mains power, provided by the PSA030 power supply.
- Automatic power up with Mains power restoration.
- Independent watchdog systems in both the Model 831 meter and the embedded computer in the 831-INT-ET will restart the system in the event of system fault.
- Quick SBC power on timing.
- USB hub power (and USB devices deriving power from the Hub) is turned on or off as needed by the Model 831 for efficient power management.

USB Hub

- 4-port powered USB hub for peripherals.

- Directly power devices such as:
 - **SEN031**: weather station.
 - **COM-RV50-DC-U/E**: Wireless Ethernet Gateway.
 - **DVX011**: USB to serial adapter.
 - **GPS001**: GPS receiver.

Digital Input/Output

- 2 digital I/O control lines (1 in, 1 out).

Internet Connection

- 831-INT-ET provides an RJ45 Ethernet connector for broadband, Internet connection. This provides:
 - Faster communication speed.
 - Remote firmware upgrade.
 - Real-time streaming of data.

Mounting

- Compact design cradles the Model 831 and provides for mounting.

Standard Accessories

The 831-INT is delivered with the following accessories:

- **PSA030**: Power Supply.
- **CBL159**: USB A to Mini-B USB cable, (2 provided).
- 1/4"-20 x 5/8" Stainless Steel Thumb Screw with spacer and washer for mounting the 831-INT to a panel.
- Screw Driver.
- 5-position pluggable screw terminal, (2 provided).
- **I831.04**: 831-INT and 831-INT-ET User Manual.

Optional System Accessories

The 831-INT is an accessory of the Model 831 Sound Level Meter that, when combined with the following accessories, form the core of a noise monitoring system.

Sound Level Meter

- **Model 831:** Sound Level Meter.

Outdoor Microphone Preamplifiers

- **426A12:** Outdoor Microphone Preamplifier.
- **PRM2103-FF** Outdoor Microphone Preamplifier.

Environmental Enclosure

- **EPS031:** Small environmentally protected, pole mountable enclosure for AC mains power, with 9 AH battery, which supports the Model 831, 831-INT and accessories.
- **EPS043:** Large environmentally protected, pole mountable enclosure for AC mains power, with 9 AH battery, which supports the Model 831, 831-INT and accessories.

Sensors

- **SEN031:** Vaisala WXT520 multi-metric weather station.

GPS Receiver

- **GPS001:** GPS Receiver, provides location and time synchronization.

Communication Devices

- **COM-RV50-DC-U/E:** Raven XE G3 Ethernet Gateway with DC power cable.

Signal/Control Cables

- **CBL152:** Signal Cable, 426A12 to 831-INT, 20 ft (6m).
- **CBL153:** Control Cable, 426A12 to 831-INT, 20 ft (6m).
- **CBL167:** Cable for SEN031 weather station. Connects to the Model 831 through 831-INT with DVX008A.

Battery Cables

- **CBL147:** 831-INT Single Battery Connection, 2 ft (0.6m).
- **CBL149:** Cable 831-INT to Battery, 12 ft (3.7m).

- **CBL160:** Cable connecting 831-INT to solar charger, 2 ft (0.6m).
- **CBL161:** Cable for 100 AH battery to solar charger, 10 ft. (3m).

Assembly and Configuration

This chapter provides the 831-INT assembly information necessary for configuring the device.

Electrical Connection Overview

The following figures and tables describe the electrical connections available on the 831-INT.

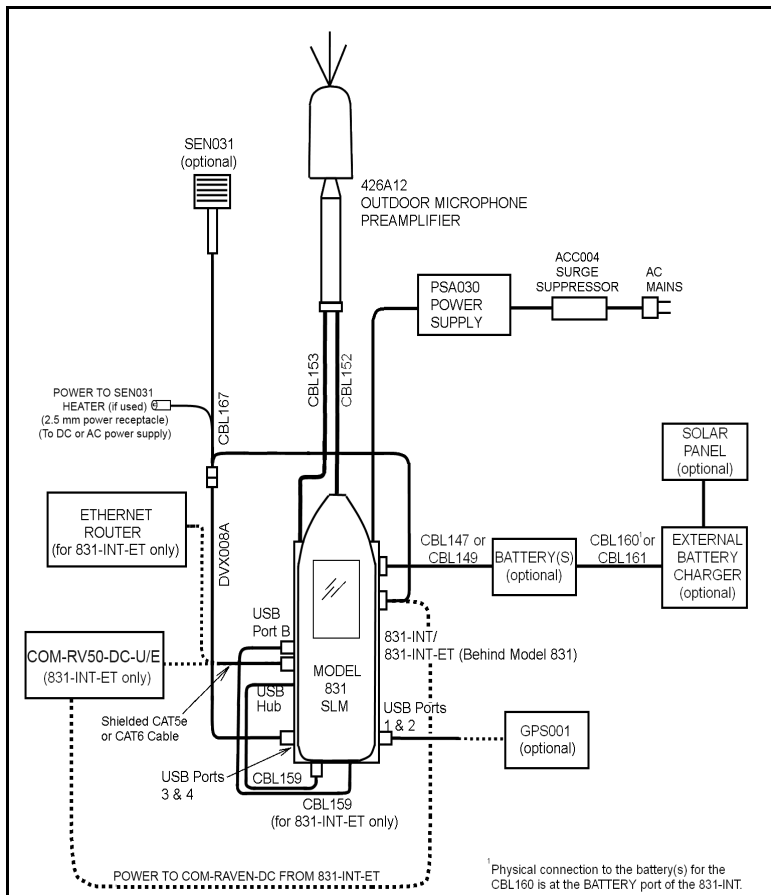

FIGURE 2-1 Connection Block Diagram



FIGURE 2-2 831-INT with Model 831: Right Side View

831-INT Connector	Usage	Cable
USB PORTS 1 and 2	gateway, GPS	Direct connect or USB Cable
AUX POWER & LOGIC I/O	Provides power for auxiliary devices, switch and indicator light, SEN031 Weather station, and Sierra Wireless RV50.	CBL167 for SEN031 weather station, otherwise user supplied.
EXTERNAL CHARGER	External Battery Charger input, optional ¹	
BATTERY	One or two, 12-volt sealed lead acid batteries	CBL147 or CBL149. See “Battery Connection” on page 2-5
¹ In the event that a charger with more capacity is needed		

Table 2-1 Connections to 831-INT or 831-INT- ET: Right Side



FIGURE 2-3 831-INT with Model 831: Top End View

Model 831 and 831-INT	Usage	Cable
Mains Power	PSA030 15 VDC Power Supply	Included with PSA030
Preamp Control	426A12 or PRM2103-FF Outdoor Microphone Preamplifier Control connector	CBL153 (426A12) or CBL208 (PRM2103-FF)
Model 831 Preamplifier (nose cone)	426A12 Outdoor Microphone Preamplifier Signal connector	CBL152 Signal Cable

Table 2-2 Connections to 831-INT and Model 831: Top End



FIGURE 2-4 831-INT-ET with Model 831: Left Side View

831-INT Connector	Usage	Cable
USB HUB INPUT	Connect CBL159 between USB HUB INPUT and the Model 831 USB host connector labeled AUX	CBL159
USB Ports 3 and 4	SEN031 Weather Station, etc.	CBL167 for SEN031 weather station

Table 2-3 Connections to 831-INT or 831-INT- ET: Left Side

831-INT-ET Connector	Usage	Cable
USB A	Not used.	
USB B	Connect CBL159 between USB B and USB Connector on 831	CBL159
Ethernet	Network Device	CAT5e or CAT6 Shielded Network cable

Table 2-4 Connections available with 831-INT-ET

Battery Connection

There are two cables available for connecting the batteries to the 831-INT.

Single Battery

The CBL147 is used with a single battery such as the BAT014, a 9 AH sealed lead acid battery. The CBL147 uses a 3AG 4A Slo-Blo Littelfuse (p/n 0313004.HXP).

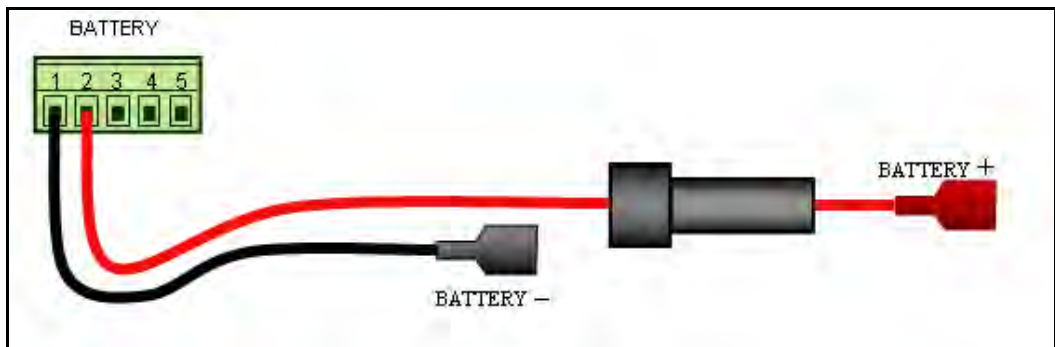

FIGURE 2-5 CBL147

Underground Battery EPS035

The EPS035 is an underground vault/enclosure with a 100 AH deep cycle sealed lead acid battery which is usually used

with permanent solar powered installations. The CBL149, which is 12 feet long and has a remote battery temperature sensor, is designed for use with this battery. The CBL149 uses a 3AG 4A Slo-Blo Littelfuse (p/n 0313004.HXP.) Figure 2-6 shows CBL149.

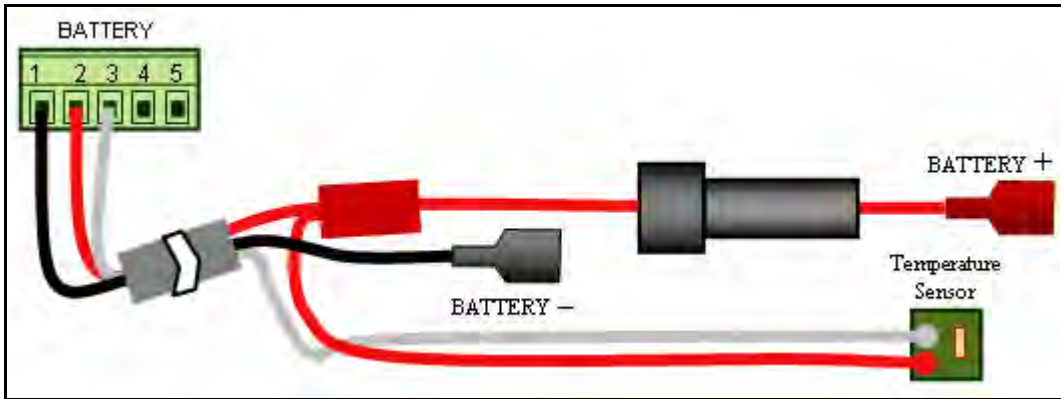

FIGURE 2-6 CBL149

It is possible to utilize a temperature sensor inside the 831-INT instead of the temperature sensor included with the cable. See “Battery Temperature Sensor” on page 2-11, for further detail.

The 831-INT is delivered with internal temperature compensation enabled for use with CBL147.

To achieve good performance and long battery life, the charging of the battery can be optimized by monitoring the battery temperature. Attach temperature sensor to the battery by peeling off backing material and pressing adhesive coated side of sensor to the side or top of the battery.

Set the internal controls to use the External Temperature Sensor. See “Battery Temperature Sensor” on page 2-11 for more details.

Solar Charger Cables

The CBL160 is used to connect power between a solar charger and the 831-INT. CBL161 is used to connect the solar charger to the batteries.

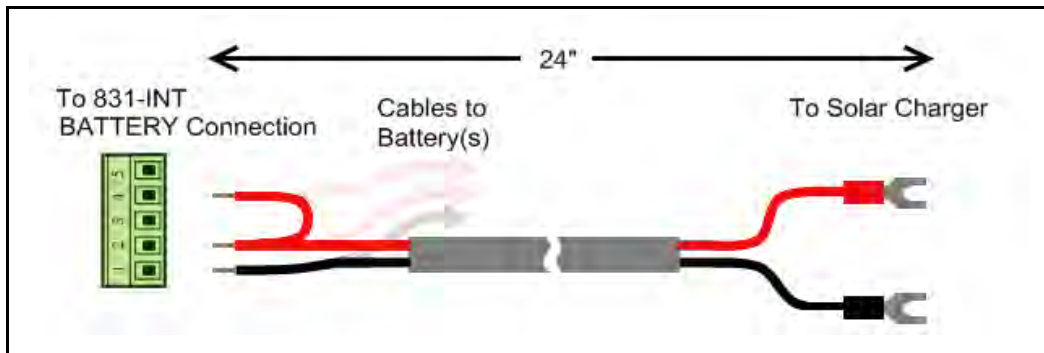

FIGURE 2-7 CBL160 Cable to Solar Charger

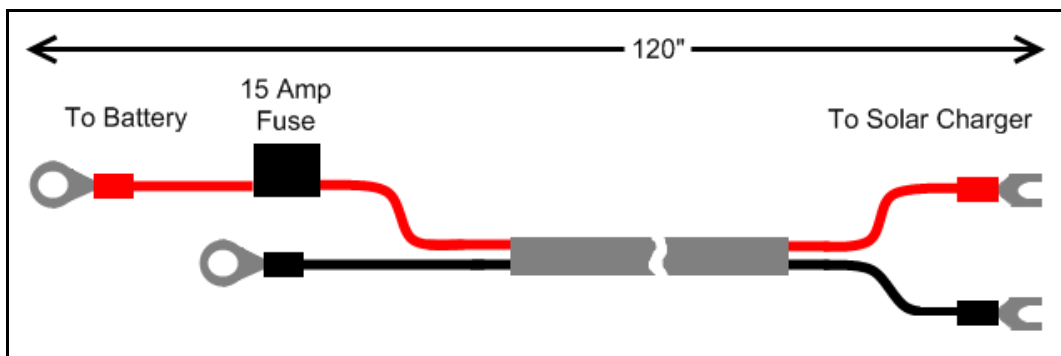

FIGURE 2-8 CBL161 Cable 100 AH Battery to Solar Charger

Router Battery Connection

A Sierra Wireless RV50, GX450, and LS300 can be connected to the 831-INT-ET as a power source by using a DC cable as shown in FIGURE 2-9 Router DC Cable Connection. The Ethernet cable will need to be inserted to finish the router's connection to the 831-INT-ET.

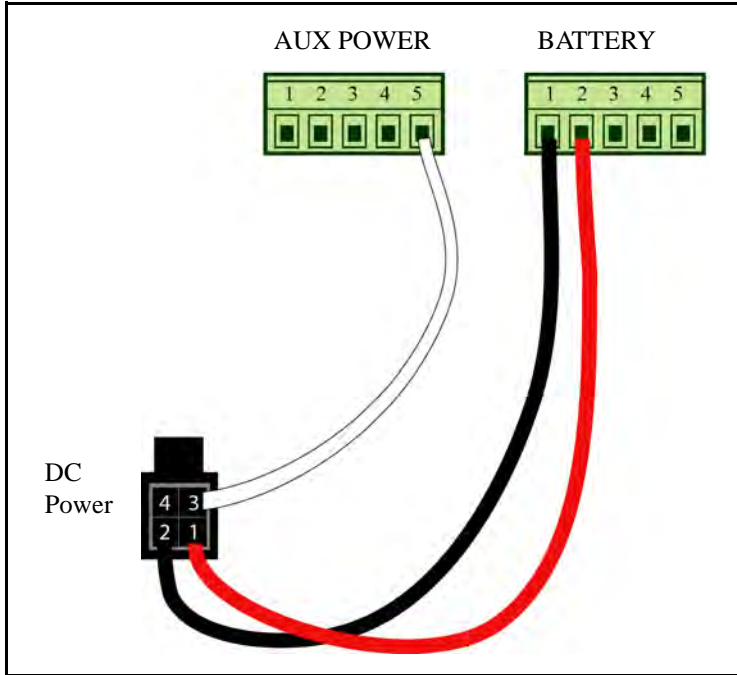

FIGURE 2-9 Router DC Cable Connection

Assembly Diagram

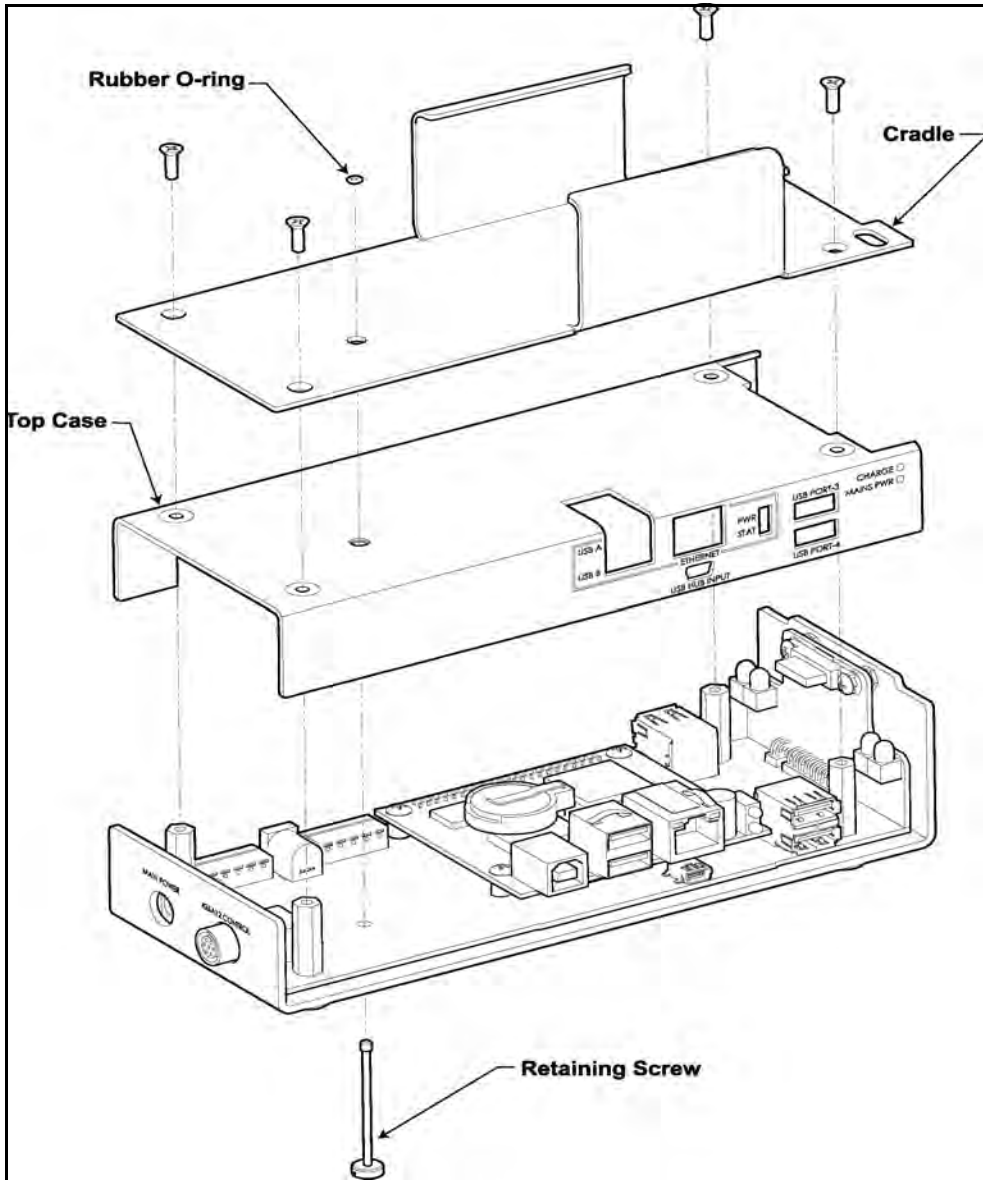

FIGURE 2-10 831-INT Exploded Assembly

Internal Jumpers

The 831-INT has jumpers that are used to enable or disable 831-INT features, including the following:

- Watchdog timer for automatic reset if failure occurs
- External temperature sensor for improved battery charging
- Built in lead acid battery charger

To gain access to these jumpers, do the following:

WARNING! Do not remove the power from the 831-INT before properly shutting down the Model 831 and then waiting for the green **SYSTEM ON LED** to stop flashing, see “Proper Shutdown Method” on page 3-4

- Shut down the Model 831 and remove all cables, including the power cable.
- Remove the Model 831 from the 831-INT.
- While doing the rest of this operation, ensure to follow good electrostatic discharge (ESD) practices. First touch metal that is known to be grounded. Then touch a bare metal part of the 831-INT before opening up the case.
- Remove the small rubber o-ring that is found on the long captured the Model 831 retaining screw.
- Remove retaining screw by pulling it out as far as it can go and then unscrewing it out of the top case.
- Remove the upper four screws of the 831-INT with a Phillips screw driver.
- Remove the 831-INT's upper cradle and top case metal pieces.

This gives access to the 831-INT's circuit boards.

When the assembly is put back together, take care to ensure that the grounding tabs on the circuit board make contact with the inside wall of the enclosure, and that these tabs do not get crushed or deformed in the process. It is helpful to push them into the enclosure with a screwdriver, while placing the top enclosure case on.

Battery Charger

When using solar power or an external charger, the internal charger should be disabled.



<p>P4</p> 	<p>Charger Enabled (default) Place P4 jumpers as shown to enable internal charger.</p>
<p>P4</p>  	<p>Charger Disabled (optional) Remove the jumpers from both pin pairs of P4 to disable the internal charger. This will permit the use of an external charger or solar charger to directly charge the battery. Keep the jumpers in a secure place so that they are handy if operation needs to be changed later. They can be placed on the side pins for safe keeping (as shown below).</p>

Table 2-5 Internal Battery Charger Enable

Battery Temperature Sensor

The 831-INT supports temperature compensated charging for 12V sealed lead-acid batteries. An internal sensor provides temperature compensation without physically contacting the battery and offers reasonable temperature compensation when the battery and the 831-INT are in close proximity (in the same enclosure). For this internal temperature compensation configuration use battery connector cable CBL147.

For batteries using the CBL 149, use the External Battery Temperature Sensor configuration.



<p>P3</p> 	<p>Internal Battery Temperature Sensor (default) Select the temperature sensor that is internal to the 831-INT by placing a jumper on the top pin pair of P3 as shown. The bottom jumper is a spare.</p>
<p>P3</p> 	<p>External Battery Temperature Sensor (optional) Select the temperature sensor that is attached to the battery by placing a jumper on the middle pin pair of P3. The bottom jumper is a spare. Used with CBL149</p>

Table 2-6 Select Battery Temperature Sensor

Watchdog

Caution: Remove the AA batteries from the Model 831 for proper functioning of the watchdog.

For a description of the watchdog function, see “Watchdog Cycle Time:” on page A-12.



<p>P2</p> 	<p>Watchdog Enable (default) The watchdog will cycle the power to the Model 831 off and on in the event that the Model 831 stops responding to the 831-INT for a period of 12 minutes. The watchdog is enabled when the upper right pins of P2 are connected by a jumper as shown in the figure and the bottom right pin remains open.</p>
<p>P2</p> 	<p>Watchdog Disable The watchdog is disabled when the bottom right two pins are connected by a jumper and the upper right pin is open as shown in the figure.</p>

Table 2-7 Watchdog on 831-INT Circuit Board

Embedded Computer Enable

This jumper is factory set and should not require modification.

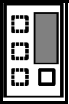

<p>P2</p> 	SBC in 831-INT-ET is enabled.
<p>P2</p> 	No SBC unit (default) is configured as 831-INT.

Table 2-8 Configuration for 831-INT/831-INT-ET

Fuses

All fuses listed below are Littelfuse p/n 0454003, Slo-Blo 125V 3A or equivalent, unless otherwise noted.

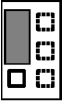
- F2 - Preamplifier Fuse (Littelfuse 0453.500MR, very fast acting, 0.5 A, 125V)
- F6 - External Charger Fuse
- F7 - Fuse for battery #1
- F8 - Fuse for battery #2
- F9 - Fuse from mains power to primary circuit board and internal SLA charger
- F10 - Fuse for Model 831, USB hub, and embedded computer when configured for a 831-INT-ET

See FIGURE 2-11 for locations of these fuses on board.

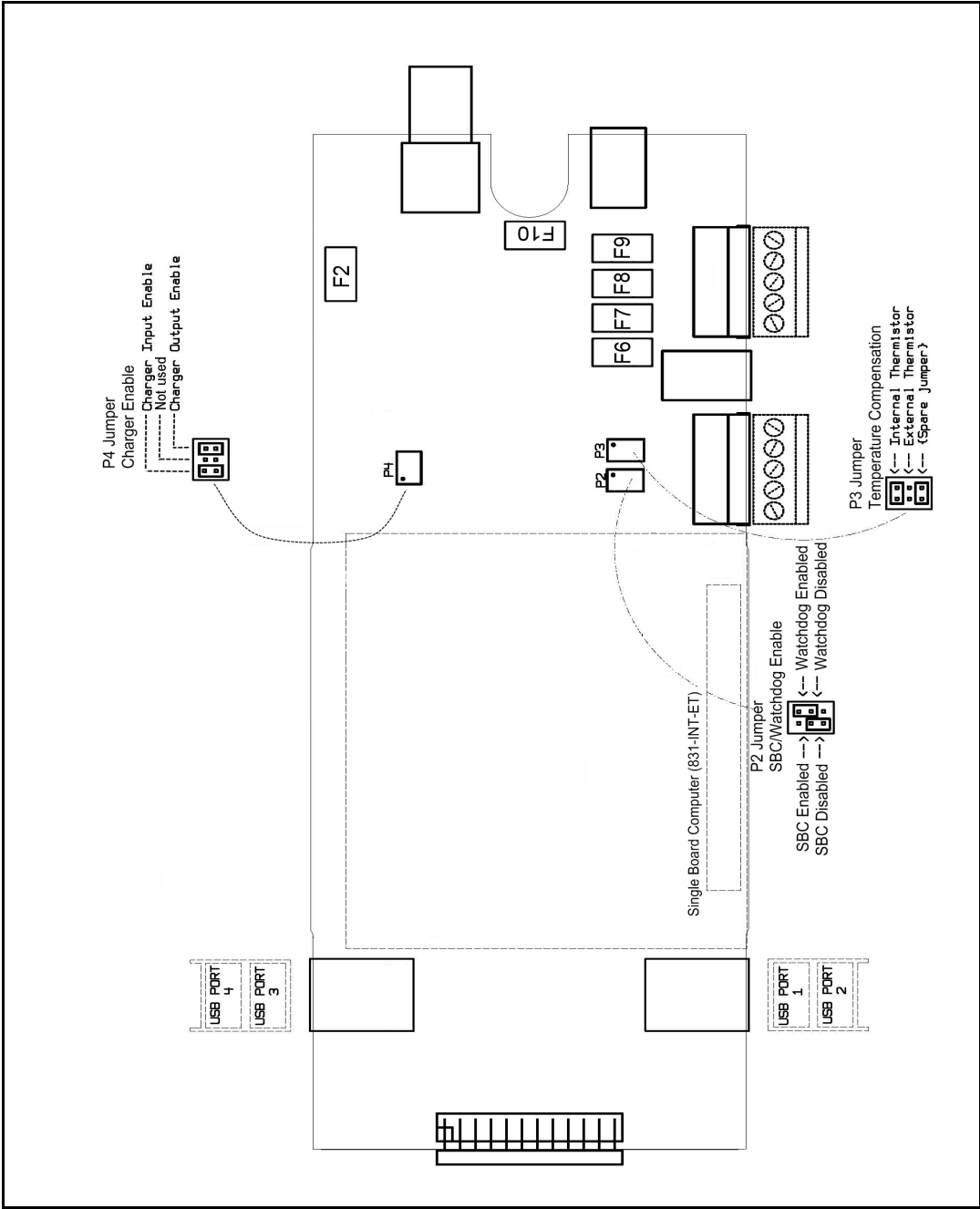

FIGURE 2-11 831-INT Circuit board

Placement of Model 831

When properly inserted, the screw will align with the Model 831 battery door security nut.

The Model 831 slides in between the two vertical guide plates on the sides of the 831-INT as shown in FIGURE 2-12.

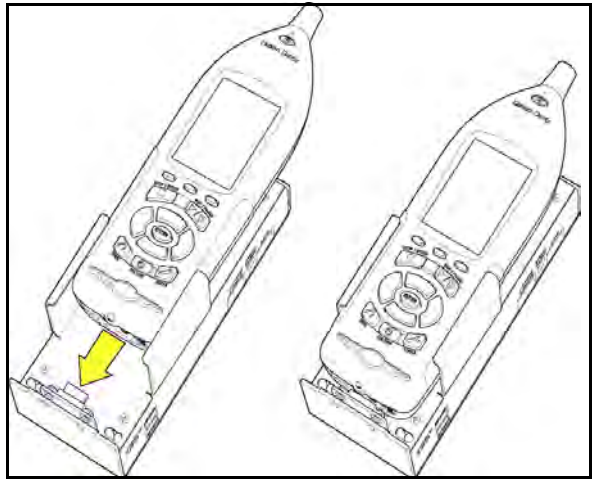

FIGURE 2-12 Model 831 Placement

Caution: For proper watchdog operation, remove the AA batteries within the Model 831.

Hold the 831-INT in one hand, in such a manner that the retaining screw which will secure the Model 831 to the 831-INT drops into the retracted position below the upper surface of the 831-INT.

With the other hand, slide the Model 831 between the two vertical guide plates, back end (with connectors) first and press until the electrical connector on the end plate is aligned and inserted firmly into the I/O Connector of the Model 831.

From beneath the 831-INT, manually tighten the retaining screw to secure the Model 831 firmly onto the 831-INT.

Removal of Model 831

Turn off the Model 831 prior to disconnecting from the 831-INT.

When removing the Model 831 from the 831-INT, the Model 831 must be kept out of the cradle for at least 5 - 10 seconds before re-inserting to have the automatic power-on feature work properly.

Mounting 831-INT in an EPS031 or EPS043

A 1/4-20 x 5/8" stainless steel thumb screw with spacer and washer is provided with the 831-INT for mounting it to a panel. Screw into the threaded insert on the back of the 831-INT as shown in FIGURE 2-13. Ensure that the convex side of the curved washer is facing towards the 831-INT.

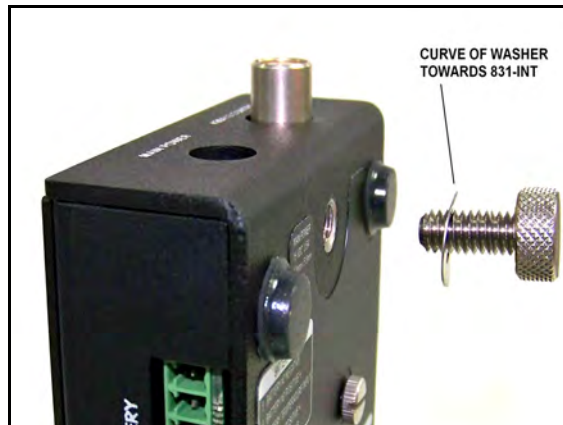

FIGURE 2-13 Placement of Stainless Steel Mounting Hardware

The 831-INT is then suspended from a mounting plate which has a key hole at the top to engage the thumb screw as shown in FIGURE 2-14. When the 831-INT is positioned properly, tighten the thumb screw securely.



FIGURE 2-14 Mounting of 831-INT

Configuring Routers for 831-INT-ET

Overview

The 831-INT-ET enables the Model 831 to communicate using broadband network technology.

The 831-INT-ET is designed to be placed on a private network with access to the Internet through a router. The 831-INT-ET ships pre-configured to support DHCP addressing, allowing the 831-INT-ET to work in a typical private network. To allow the 831-INT-ET to be accessible from the Internet, port forwarding needs to be set up in the router and the DHCP server configured to provide a reserved address to the 831-INT-ET. You will also need to configure your firewall to allow the required ports.

Proper installation will require someone familiar with router, DHCP, and firewall configuration, who also has administrative rights for these devices.

Configuration

A typical network configuration is shown in Figure 2-15.

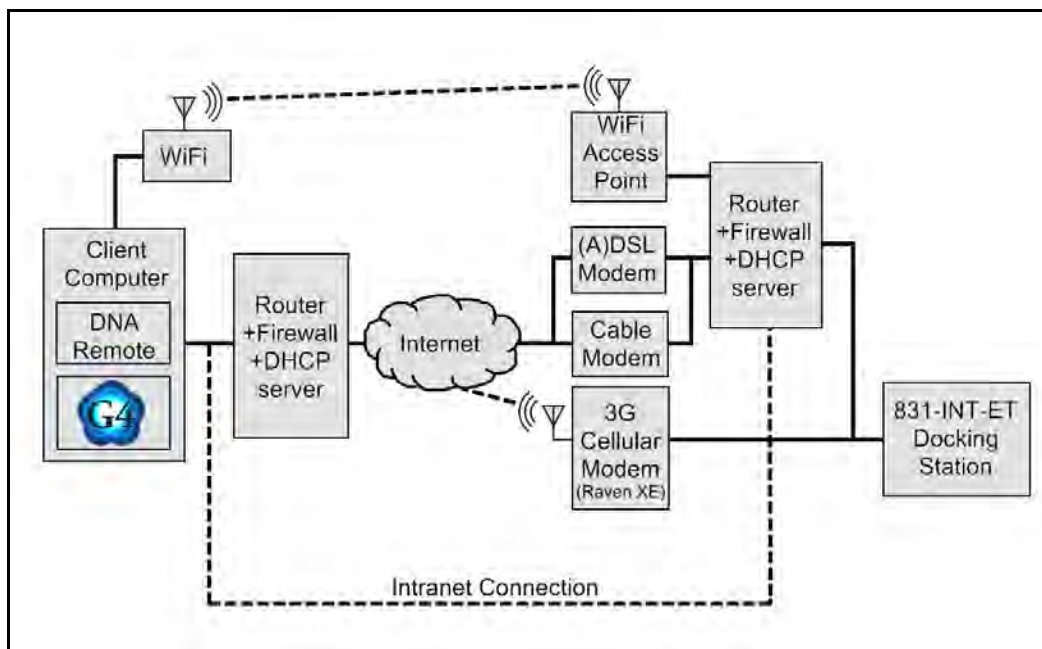

FIGURE 2-15 Typical Network Configuration

Viewing the Private IP Address

If the DHCP is not found, see “The IP Address on Model 831 is not shown.” on page B-6.

The private IP address shown on the meter is not automatically mapped to the public IP address for your organization’s network; therefore, network connectivity will require the assistance of your IT professional.

You can view the private IP address of the Model 831 when connected to the 831-INT-ET by pressing the Tools button on the meter and selecting Communications. Figure 2-16 shows the **Network** tab in Communications:

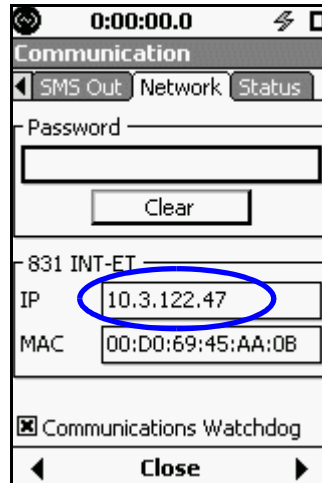

FIGURE 2-16 Private IP Address

Router Configuration

The 831-INT-ET MAC address is needed to configure the router for DHCP. The MAC address is located on the back label of the 831-INT-ET (see FIGURE 2-17). After configuring the router for the 831-INT-ET, use the IP address or host name and port number that is needed in order to connect the G4 LD Utility software to the Model 831 through the 831-INT-ET via Ethernet. For proper functionality, configure the router as follows:

1. Use a static IP address for the Internet side of the router. This is the address to which you will communicate with the Model 831 using G4 LD Utility or other software. To get a static IP address, request one from your network service provider.

2. The private side of the router should support DHCP. This is a common feature found on almost all routers. If devices other than the 831-INT-ET are connected to the client side of the router, the DHCP server in the network adapter should be configured to always provide the same IP address to the 831-INT-ET. This is done by configuring a reserved IP address for the MAC address found on the label on the 831-INT-ET.
3. The router needs to be configured to port forward from the static address (Internet side) to the 831-INT-ET. The default TCP/IP ports are **2001**, **80**, or **443**, which need to be forwarded and also allowed through any existing firewall.

*For Secure Sockets Layer (SSL) security, use TCP/IP port **443**, which requires a password.*



FIGURE 2-17 831-INT-ET MAC Address

Operation

This chapter provides a description for properly operating the 831-INT with the Model 831 sound level meter.

Status Indicators

When operating the 831-INT and Model 831 sound level meter, ensure that the meter is properly shut down before disconnecting power from the 831-INT. Otherwise, the resulting improper shutdown may corrupt the flash memory in the Model 831 or 831-INT-ET.

The 831-INT provides four LEDs to indicate status. They are as follows:

- Mains Power (MAINS PWR)
- Battery Charger Status (CHARGE)
- System On Status (SYSTEM ON)
- USB Status (USB HUB)

Figure 3-1 shows the location of the status indicators.

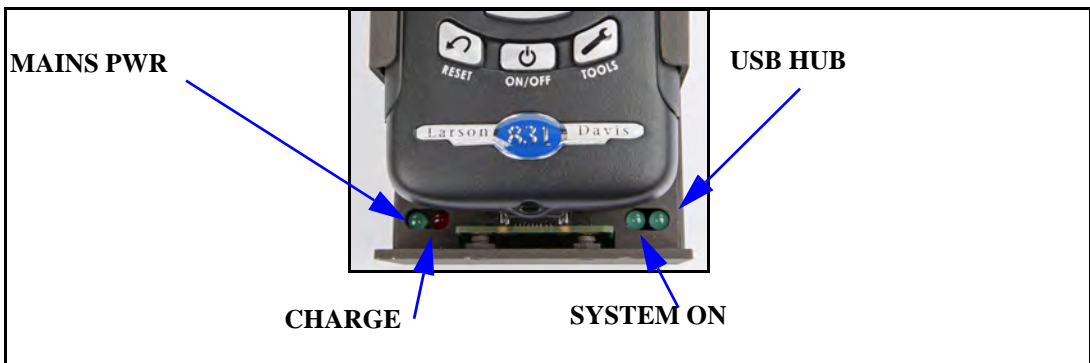

FIGURE 3-1 LED Status Indicators

Mains Power/External 15V DC Power

The green **MAINS PWR** LED is illuminated when the external supply is greater than 13.8 volts. Connect the PSA030 power supply to the Mains Power connector to power the 831-INT, an attached Model 831, and charge optional batteries. The mains or battery voltage can be read on the Model 831 display (refer to the Model 831 Manual).

Disconnecting 831-INT from the Model 831

Shut off the instrument properly. An improper shut down or abrupt power loss can result in corrupted or damaged flash memory.

Turn off the Model 831 prior to disconnecting the 831-INT from the Model 831.

Battery Charger Status

The Model 831 internal battery charger status is indicated by the red **CHARGE** status LED, shown in FIGURE 3-1:

- **Illuminated, steady:** Rapid charging
- **Illuminated, winking:** Float charging
- **Slow flashing:** Low battery recovery
- **Fast flashing:** Fault, thermistor or no battery
- **Not Illuminated:** Charger Off

System On Status

WARNING! *When turning off the Model 831 sound level meter, wait until the green **SYSTEM ON** LED has finished flashing quickly and has turned off before disconnecting power from the 831-INT. See “Proper Shutdown Method” on page 3-4.*

The green **SYSTEM ON** status LED indicates the system is supplied with power either by the battery or by the Mains Power connector. Table 3-1 indicates the states for this LED:

Instrument	LED Indication	State
831-INT	ON, with two blinks per meter heart-beat	On with normal power
831-INT-ET	ON, with alternating fading and brightening, according to the pace of heartbeats from the meter or SBC**	On with normal power

Instrument	LED Indication	State
831-INT or 831-INT-ET	Flashing quickly	Model 831 has been turned off and SBC is shutting down (do not disconnect power in this state)
831-INT or 831-INT-ET	Flashing quickly for two minutes	Power shut off is imminent due to watchdog
831-INT or 831-INT-ET	Flashing quickly	Low battery shut off is imminent
831-INT or 831-INT-ET	Flashes once every second	Forced power off
831-INT or 831-INT-ET	Flashes once every four seconds	Model 831 and SBC are in normal power off
831-INT or 831-INT-ET	Flashes once every eight seconds	Low battery shutoff (will turn on when battery recovers 12.5 V or more or if mains power is connected)

***The number of minutes since the last heartbeat from either the Model 831 or the SBC determines the number of seconds that the LED stays on in this mode before fading. For example, a heartbeat once per minute is indicated by the LED staying lit one second before fading.*

Table 3-1 System On LED States

USB Status

When the USB Host port is On, the green **USB HUB LED** shown in FIGURE 3-1 will be illuminated.

The USB Host port power is controlled by the Model 831. See the Model 831 manual for more details.

831-INT-ET Operation

WARNING! Connect all cables to the 831-INT-ET prior to powering ON.

The SBC in the 831-INT-ET will boot up with the following sequence:

1. The green **SYSTEM PWR LED** will turn on.

2. If mains power is being used, the green **MAINS PWR** LED will turn on.
3. The Ethernet status LED's (green and orange) will initially be off, but will eventually come on and stay on. They will flicker at the presence of data traffic.
4. A few minutes after power on, the SBC will be ready for remote communications to the Model 831 through Ethernet connections.

Proper Shutdown Method

If the 831-INT-ET is not properly shut down, damage may occur to the system. To shut down safely, follow these steps:

- Step 1** Power **Off** the Model 831.
- Step 2** Red mains power LED will turn on.
- Step 3** Wait until the red mains power LED light goes dark.
- Step 4** You can now disconnect the 831-INT-ET or cables safely.

Connecting to Model 831 through 831-INT-ET using G4 LD Utility

To establish a TCP/IP type connection from G4 LD Utility (G4) software to the Model 831 through the 831-INT-ET, follow these steps:

For information on the 831-INT-ET's IP Address see "Configuring Routers for 831-INT-ET" on page 2-17

Step 1 Connect a router via Ethernet cable to the 831-INT-ET.

Step 2 Power the Model 831 ON.

Step 3 Launch G4 LD Utility on a PC, click **Connect**.

Specify port numbers 80 or 2001. If using Secure Sockets Layer (SSL) security, enter port number 443, which requires a password.

Step 4 Select **831** and **TCP/IP** options. Then press **Add Meter**, a new empty meter line will appear. See FIGURE 3-2 "G4 LD Utility Connect to Meter"

Step 5 Enter the following information into the row:

- Name (not required)
- IP Address
- Port number
- Password (if applicable)

Step 6 Click **Connect**.

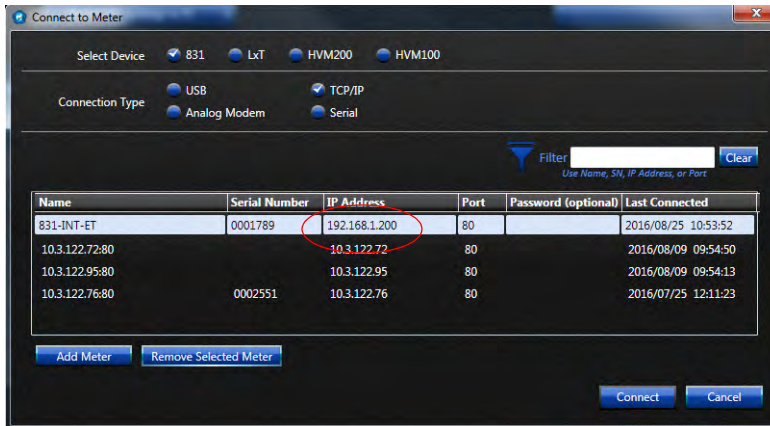

FIGURE 3-2 G4 LD Utility Connect to Meter

Connecting to Model 831 through 831-INT-ET using SLM Utility-G3

To establish a TCP/IP type connection from the SLM Utility-G3 software to the Model 831 through the 831-INT-ET, follow these steps:

Step 1 In SLM Utility-G3, click **Connection > Remote > Internet**. This will bring up the Remote Internet Site connection box. (See FIGURE 3-3.)

Step 2 Enter the host name of the router or the public IP address for the 831-INT-ET IP address and also the port number. When configured as described in this manual, the IP address or host name of the Model 831 is the public address of the router. For more information on this see “Configuring Routers for 831-INT-ET” on page 2-17.

Refer to the *SLM Utility-G3 Manual* for more information on its various operations and functions.

Step 3 Click **Connect**. This will connect SLM Utility-G3 to the Model 831 through TCP/IP.

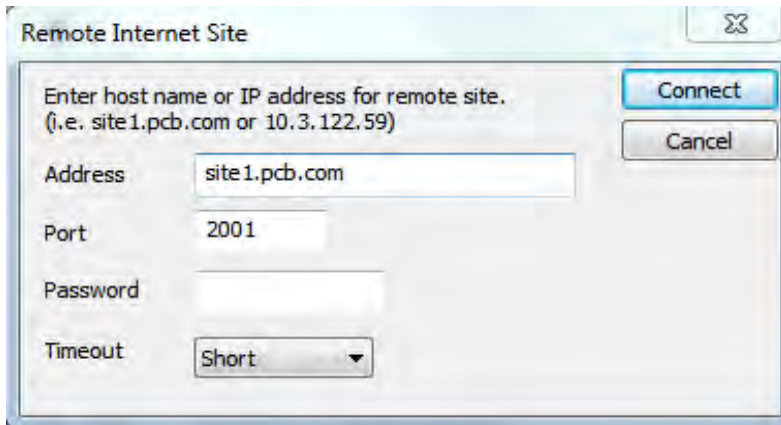

FIGURE 3-3 Remote Internet Site Connection Box using Remote Site Host Name

Battery Charger Operation

The 831-INT battery charger is designed to automatically charge an 12V external sealed lead acid battery. The four charger modes and the red **CHARGE** LED operation are shown in Table 3-2.

The **CHARGE LED** indicates sensor temperature by the duration it remains on between blinks. At 0 °C (32 °F), the LED remains on for 5 seconds; at 25 °C (77 °F), the LED remains on for 3 seconds, and at 60 °C (140 °F), the LED remains on for 1 second.

Mode/Status Indication

Charger Mode	Charge LED (Red)
Off: Disabled, or no mains power	Off
Rapid Charge	On
Float Charge	On, winking once every few seconds
Low Battery Recovery	Slow flashing
Fault, thermistor, or no battery	Fast Blinking

Table 3-2 Charger Mode/LED Indication

If the battery becomes drained, the Model 831 will shut off and the 831-INT will discontinue supplying power to peripherals to protect the battery and enhance service life.

The time that it takes to fully charge a battery using the 831-INT can be estimated from the following equation:

$$T=1.6 \times C$$

where

T is time in hours

C is battery capacity in Ampere Hours (AH)

For instance, a 42 AH battery would take $1.6 \times 42 = 67.2$ hours to fully charge.

Battery Matching

It is important when using dual batteries to ensure that they are of the same make, model, charge level and age. To ensure that new batteries are at the same charge level you can:

- Charge each battery individually and then put them in-service together. (This is the preferred method.)
 - Install the first battery.

The 1 Ampere charge available from the 831-INT can charge batteries with total capacities up to 42 AH. For batteries with higher capacities than this, an external charger should be used and the internal charger disabled (the PSA030 will still be used to power the system from Mains Power). See “Battery Charger” on page 2-11 for additional detail.

- Charge the first battery until the charge status indicates float mode.
 - Disconnect the first battery.
 - Install the second battery.
 - Charge the second battery until the charge status indicates float mode.
 - Reinstall the first battery with the second battery as they are now matched in charge.
- Measure the voltage of the two individual batteries. If they are within 1/2 volt of each other they may be installed at the same time.

Solar Power Operation

For more information on external battery shutoff, see the Model 831 Manual.

The 831-INT has provisions to work with solar power. The solar charger connects directly to the battery and the battery connects to the BATTERY connector of the 831-INT. To protect the battery, the system will shut off if the battery becomes discharged. This shut-off voltage defaults to 10.8 VDC, but can be programmed in the Model 831 settings. When the battery voltage reaches 12.5 VDC for at least two minutes, the system will automatically power on.

In the event that the system was powered off because of a low battery, the user can manually power up the system by pulling out the battery connector to the 831-INT for 30 seconds and then plugging it back in. This can be done as long as the battery voltage is greater than 10.8 volts.

System SLA Battery Capacity and Run-time

In the event that the mains power is lost to the 831-INT or when the solar charging system is not supplying adequate power to the 831-INT, the 831-INT will switch to backup SLA batteries. To roughly estimate the total system battery run-time off this SLA battery, one needs to first calculate the total system power requirement. The power consumptions of the various system devices involved are listed in *Table A-4 'Device Power Consumption'*. After summing the total system power, to find the battery run-time approximation, use the equation:

$$\text{Battery run-time} = (C \times 12.0 \times 0.8) / \text{Total System Power}$$

C is the total batteries capacity in amp-hours.
 12.0 is the nominal voltage of the batteries.
 The 0.8 factor is a safety margin multiplier.

An example system might be something like running a Model 831, 831-INT-ET, 426A12 (microphone bias on), GPS001 (in auto mode), SEN031, and COM-RAVEN-DC 3G gateway, with a 9.0 amp-hour back-up SLA battery. To calculate the battery run-time, we first sum the total system power. The total system power calculations for this example are found below in *Table 3-3 'Total System Power Example'*:

System Device	Power (watts)
Model 831 with 831-INT-ET	4.4
426A12 outdoor preamplifier	1.4
GPS001 GPS receiver (auto mode)	0.05
SEN031 Vaisala weather station	0.04
COM-RAVEN-DC 3G gateway (idle)	0.96
Total System Power	6.9
<i>Note: It is assumed that the COM-RAVEN-DC Raven gateway will be running in idle for the majority of this time.</i>	

Table 3-3 Total System Power Example

The next step would be to calculate the battery run-time:

Battery run-time = (9.0 amp-hr x 12.0 volts x 0.8) / 6.9 = 12.5 hours.

If the system is expected to be running in cold temperatures, you will also need to multiply this calculated battery run-time by a cold temperature multiplier found in Table 3-4:

Temp (°C)	Battery Run-time Multiplier
21	1.0
10	0.90
0	0.85
-10	0.75
-20 ¹	0.65
-30	0.53

¹Note: Many SLA batteries (including those sold with the Larson Davis noise monitoring systems) can be discharged at temperatures above -40 °C, but can only be charged at temperatures above -20 °C.

Table 3-4 Battery Run-time Temperature Multipliers

So, if the above example system were to run at a possible extreme temperature of -20 °C, the backup battery run-time would be:

$$12.5 \times 0.65 = 8.1 \text{ hours.}$$

Battery lifespan will be dependent on what extent the battery is being discharged. If the SLA battery is being used in a backup type application, the typical battery life span is approximately three to five years.

*For more information, see **Lifecycle information from Power-Sonic corporation's publication entitled Sealed Lead-Acid Batteries Technical Manual.***

If the battery is being used in a cyclical discharge scenario (i.e. solar powered system), the battery lifespan can vary according to what depth the battery is discharged to. For example, if the battery is being discharged 100% of the capacity each cycle, a typical battery will only be able to be cycled approximately 200 times. Cycling it down by 50% would give approximately 500 cycles. Cycling it down by only 30% would give approximately 1000 cycles.

If the system is being charged by solar panels, other factors come into play such as solar panel power output, location's latitude, time of year, amount of sun exposure per day, etc.

A

Technical Specifications

The specifications contained in this chapter are subject to change without notice.

Physical Characteristics

Length:

7.68" (19.5 cm)

Width:

3.00" (7.62 cm)

Height:

3.02" (7.66 cm)

Weight:

831-INT: 16.4 oz (465g)

831-INT-ET: 17.5 oz (496g)

Environmental Specifications

Operating Temperature:

- 40 °C to 70 °C

Storage Temperature:

- 40 °C to 70 °C

Humidity:

10 to 95% RH, non-condensing

831-INT-ET Docking Station with Ethernet

The 831-INT-ET adds Ethernet communication capability to all features present in the 831-INT. The 831-INT-ET contains the following additional features:

- Embedded computer.
- Ethernet connector.
- Additional USB Ports A and B. Use USB Port B to connect to the Model 831 USB Port.
- Expanded watchdog functionality. If USB communication between the 831-INT-ET and Model 831 is lost for more than 5 minutes the complete system will restart.

USB HUB

- Powered, providing up to 500 mA per output port
- Hub Input Connector: Standard 5-pin mini-B Jack
- Four Hub Output Connectors: Standard USB-A Host Jacks. USB ports 1 through 4.

Outdoor Microphone System

Description

This seven pin LEMO® connector interfaces to the Larson Davis Model 426A12 Outdoor Microphone System using cable CBL153.

Pin Connections:

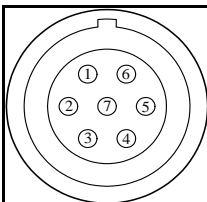

FIGURE A-2 View looking into the 831-INT's 426A12 control connector

Pin Number	Function and Specifications
1	Power Ground (return for pin 7)
2	Control Ground (return for pins 3 through 6)
3	Electrostatic Actuator On/Off (Output) On: +2.6 to +3.6V output Off: 0 to +0.3V output Electrical Impedance: 1100 ohms
4	Overload (Input) +5 V indicates system overload, 0 V is no overload
5	Sensor Clock (Output)
6	Sensor Data I/O (Input & Output)
7	Power (Output) Output Range: +10.5 to +15 VDC Maximum Load: 100 mA Fused at 0.5 Amperes, slo-blo Turns off when 831-INT and Model 831 are turned off

Table A-1 Pin Connections for 426A12 Outdoor Microphone System

Mating Connector:

- Push-Pull cable connector, 7-position
- LEMO® p/n FGG.1B.307.CLAD52Z or equivalent connector with collet
- LEMO® p/n GMA.1B.045.DA or equivalent, flex relief

Battery Charger

Description

This input provides an alternate means to charge batteries when the internal charger is disabled. The mains power input can be used to power the system, when mains power is available, so this external charger will only charge batteries. This input is connected directly to the battery terminals through fuses and provides for optional alternative battery charging. A solar charge control can be attached to this connector or, preferably, directly connected to the batteries.

Pin Connections:

Center Pin is positive battery DC voltage

Sleeve is Ground

Mating Connector:

Power Plug, 2.5 mm x 5.5 mm x 9.5 mm

Fuse

Fuse-protected at 3 Amperes, slow blow

Battery Connector

Description

This five pin connector accommodates the connection of two batteries. Use the CBL147 or CBL149 to connect to batteries. When using solar panels, use CBL160 to connect batteries.

Pin Connections:



Pin Number	Function
1	Battery #1 Negative, Ground Use 16AWG BLACK Insulated Stranded Wire
2	Battery #1 Positive Fuse Protected in 831-INT at 3 Amperes, slow blow Battery voltage: 12 VDC Nominal, 16 VDC maximum Use 16 AWG RED Insulated Stranded Wire

Table A-2 Pin Connections for Battery Connector

Pin Number	Function
3	Temperature Probe Input 100 k ohm thermistor, negative temperature coefficient Connect thermistor from pin 2 to pin 3 (battery +) Recommended device: BC COMPONENTS p/n: 2322 633 83104 (leaded part) or p/n: 2322 633 53104 (surface mount part) Must be thermally connected to battery
4	Battery #2 Positive Fuse Protected inside 831-INT at 3 Amperes, slow blow Battery voltage: 12 VDC nominal, 16 VDC maximum Use 16 AWG RED Insulated Stranded Wire
5	Battery #2 Negative, Ground Use 16 AWG BLACK Insulated Stranded Wire

Table A-2 Pin Connections for Battery Connector

Mating Connector for battery and also for logic I/O AUX Power Connector:

Pluggable Screw Terminal, 5-position

PHOENIX CONTACT p/n 1803604

16 to 28 AWG Wire Size

Larson Davis part number: 6200.0008

Logic I/O & Auxiliary Power Connector

Description

This five pin connector provides connections for Logic Output and Logic Input control lines, +5 volt output and switched battery power for auxiliary devices.

Pin Connections:



Pin Number	Function
1	Ground

Table A-3 Pin Connections for Logic I/O and Auxiliary Power Connector

Pin Number	Function
2	Logic Output Open drain transistor output Capable of sinking 500 mA (maximum) Voltages up to +16 VDC On resistance less than 2 Ω to ground May be used to switch on Light-Emitting-Diodes (LED) or relays (solid-state or mechanical with protective reverse current diode) Power for LED lamps may come from pin 4
3	Logic Input +5 Volt active high input, 0 for de-asserted May be a switch from pin 4 25 k Ω resistor to ground input load
4	Auxiliary +5 Volt Supply Output +5 Volt for Logic Input switches or Logic Output LED power 250 Ω current limiting resistor
5	Auxiliary Power Supply Output +10.8 to +15 VDC to power auxiliary devices 200 mA maximum load Self resetting fuse rated at 0.5 A (@ 25 °C) Turns off when 831-INT and Model 831 are turned off

Table A-3 Pin Connections for Logic I/O and Auxiliary Power Connector

Power Specification

Power Consumption for Model 831, 831-INT, 831-INT-ET and Accessories

Device	Power (Watts)
Model 831	0.92
Model 831 with 831-INT	1.2
Model 831 with 831-INT-ET	4.40
PRM831 Microphone Preamplifier	0.22
Model 426A12 Outdoor Preamplifier (no mic bias)	1.0
Model 426A12 Outdoor Preamplifier (with 200 V mic bias)	1.4
GPS001 GPS Receiver (Auto)	0.05
GPS001 GPS Receiver (On, not auto)	0.50
SEN031 Vaisala Weather Station	0.04
MDMUSB-A Dial-up modem	0.90
COM-RAVEN-DC Raven XE gateway (idle)	0.96
COM-RAVEN-DC Raven XE gateway (transmitting)	1.50
Model 831 USB host enabled	0.30
831-INT/831-INT-ET USB hub enabled	0.30
<i>Note: Consumption values are typical with system voltage at 12 volts.</i>	

Table A-4 Device Power Consumption

See System SLA Battery Capacity and Run-time on page 3-8 for more information on power consumption of other related system equipment and peripherals, total system consumption and also backup battery capacity required.

Mains Power

Description:

The mains power input on the 831-INT and provides power to charge batteries when using the internal charger, and to run the Model 831 with USB devices.

Pin Connections:

Center Pin is +15 VDC, absolute maximum is +16 VDC

Sleeve is Ground

Mating Connector:

Power Jack, 2.1 mm x 5.5 mm x 9.5 mm

Fuse:

Fuse Protected by two 3 Amperes, slow blow fuses; one for charger and one for system operation

PSA030 Power Adapter

Larson Davis part number PSA030 power adapter is supplied with the Model 831-INT and has the following specifications:

INPUT

AC Input Voltage Rating:

100 to 240 VAC

AC Input Frequency:

47 to 63 Hz

Input Current:

1.2 A (rms) max. @ 115 VAC

OUTPUT:

Voltage:

15.0 VDC

Load Current:

0 to 3.2 A

Over Voltage Protection:

110-170% Vnom, Recycle input to reset

Over-current Protection:

110-170%, auto recovery

Battery

One or two sealed-lead-acid (SLA) batteries may be used with the Model 831-INT.

Voltage:

12 volts Nominal

Typical Battery Configurations:

9 Ampere Hour, 12V Battery, LD p/n BAT014

2 x 21 Ampere Hour, 12V Batteries for a total of 42 AH, (two of LD p/n BAT011)

Minimum Recommended Capacity:

9 Ampere Hour

Terminals:

¼" male disconnect tab or bolt on adapter

Maximum Load:

Limited by 3 Ampere fuse per battery

Internal Charger

Triple Mode Charger:

1 Ampere rapid charge mode, followed by float charge mode, with Trickle charge for deeply discharged batteries utilizing 1 A maximum charge pulses.

Rapid Charge Initiation Voltage:

V_{Battery} 10.8 to 12.0 volts with temperature compensation

Rapid Charge Termination Voltage:

V_{Battery} greater than 14.3 volts

Note: The 1 Ampere charge available from the 831-INT can charge batteries with total capacities up to 42 AH. For batteries with higher capacities than this, an external charger should be used and the internal charger disabled (the PSA030 will still be used to power the system from Mains Power). See Battery Charger on page 2-11 and Battery Charger Operation on page 3-6 for additional detail.

Float Charge Voltage:

13.8 volts, nominal at room temperature with temperature compensation.

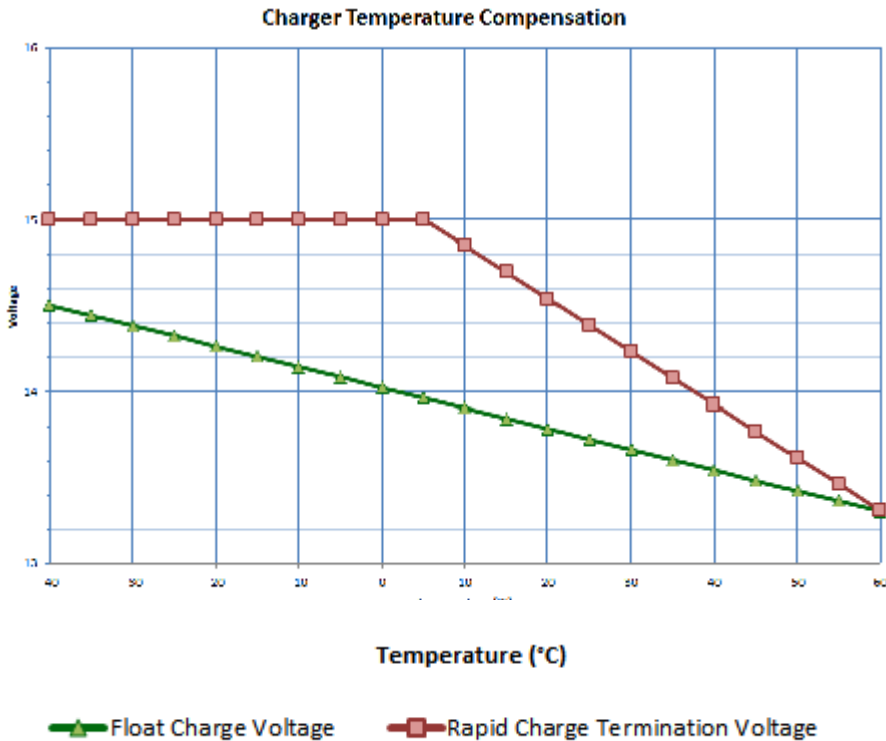

FIGURE A-3 Charger Temperature Compensation

Temperature Sensor:

Internal: used when battery is in same enclosure

External: mounts directly to battery for greater accuracy

Trickle Charge Mode:

Activated when V_{Battery} is less than 10.8 volts

Deactivated when V_{Battery} is greater than 12.0 volts

Other Electrical Characteristics

Battery Low, Shut-off Voltage:

10.8 volts (adjustable setting in the Model 831).

Switches from Mains to Battery Power when Mains voltage < 13.86 volts (battery must be sufficiently charged to operate the system).

Watchdog Cycle Time:

The 831-INT monitors the activity status of the Model 831. If no activity is sensed for 12 minutes, it will power-off the Model 831 and 831-INT for 15 seconds, after which time it will turn the power back on. It will repeat this cycle until the activity status indicates the Model 831 is operating again.

When using an 831-INT-ET there is a second watchdog monitoring the SBC. If no activity is sensed, it will behave in the same manner as the first watchdog.

NOTE: Remove the AA batteries from the Model 831 in order for the watchdog to function properly.

B

Troubleshooting

When I press the power button on my Model 831, the Model 831 does not turn on.

- If powered with mains power and the MAINS PWR status light on the 831-INT or 831-INT-ET is lit:
 - Verify that the Model 831 is seated into the 831-INT, and the 831-INT retaining screw (*FIGURE 2-10*) is securing the Model 831 to the 831-INT.
 - Ensure Model 831 hardware power switch is in ON (|) position.

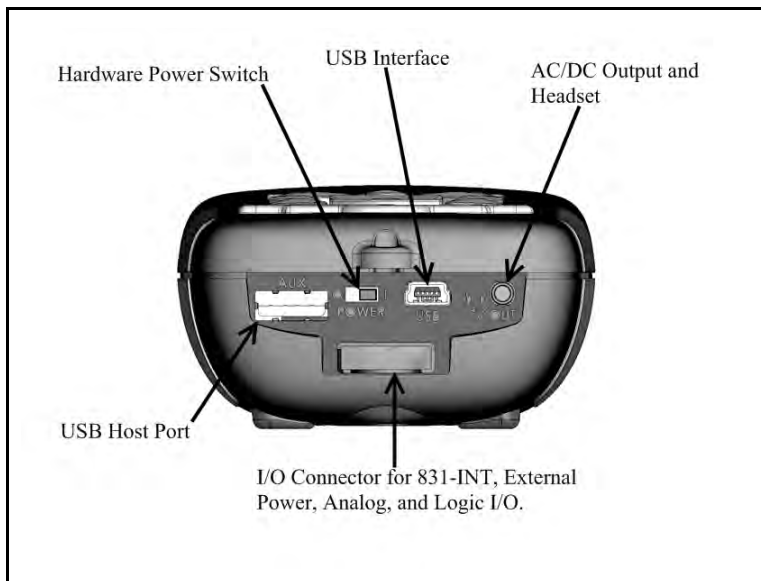

FIGURE B-1 Model 831 Bottom view

- If powered with mains power and the MAINS PWR status light is not lit:
 - Ensure that the PSA030 power supply is plugged into AC mains and to the 831-INT MAINS POWER connector.
 - Check to see if indicator light on PSA030 power supply is on.
- My 831-INT is configured for solar power or battery operation:
 - Check battery connections and voltage.

- Battery voltage must be greater than 12.5V for Model 831 to turn on automatically, observe status light on external or solar battery charger to see if the battery is being fully charged.
- If Model 831 still does not turn on, call customer support for further assistance.

During a power outage, my Model 831 or 831-INT does not continue operating.

- Check that the connections to the batteries and the 831-INT are correct.
- Verify the SLA batteries are being fully charged by checking the Battery Charger Status light on the 831-INT. This light will be flashing if the battery is not connected.
- Determine if batteries have exceeded normal service life and replace if needed.
- Check fuses.
- If Model 831 and 831-INT still does not turn on, call customer support for further assistance.

My solar charger does not charge my batteries.

- Check for and remove obstructions that will shade the solar panel.
- Check indicators on solar charger.
- Determine if batteries have exceeded normal service life and replace if needed.
- Call customer support for further assistance.

I cannot connect G4 LD Utility to the Model 831 and 831-INT-ET using an Ethernet connection.

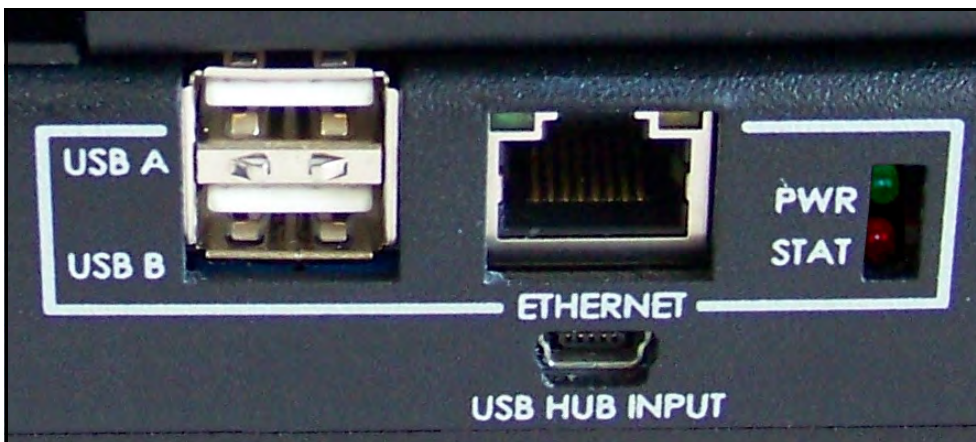

FIGURE B-2 Ethernet Status Lights and Ethernet PWR Light

- Step 1** Check with your IT professional or broadband service provider to verify that the network router is functioning properly and port forwarding rules are entered correctly.

- Step 2** Wait 3 minutes after the 831-INT-ET and Model 831 are powered up before attempting to establish an Ethernet connection.
- Step 3** Check that the CBL159 is connected from the Model 831 USB client port (marked USB on the Model 831, *Figure B-1*) to the 831-INT-ET SBC USB port marked “USB B” (See *FIGURE B-2* and *Figure B-2*).
- Step 4** Verify that the CAT5e or CAT6 Ethernet cable is attached to the network router and also to the 831-INT-ET Ethernet connector. (See *Figure B-2*.) The green LED on the Ethernet connector should be on; the yellow LED will blink with network connectivity.
- Step 5** If a USB or network cable has been temporarily disconnected after power was turned on, turn off the Model 831 and then turn it back on.
- Step 6** Verify that the IP address being used for the 831-INT-ET is correct by using the “ping” command through a command prompt.
- Step 7** If the 831-INT-ET and Model 831 power up, but the SBC green PWR light (*FIGURE B-2**Figure B-2*) on the 831-INT-ET remains off:
- Call customer service for service and repair.
- Step 8** If the 831-INT-ET still cannot connect then call customer support for further assistance.

My USB peripheral device does not work

- The Model 831 peripheral device connected by USB through 831-INT does not work (i.e. SEN031 weather station, GPS or analog gateway, etc.):
 - Check that the peripherals USB cable is connected into one of the four USB Hub ports on the 831-INT (marked USB Port 1 through 4, *FIGURE 2-2* & *FIGURE 2-4*).
 - Verify that the USB host port in the Model 831 settings is enabled. See the Model 831 Technical Reference Manual for instructions.
 - Make sure the CBL159 USB cable is connected from the Model 831 USB Host port (marked AUX on the Model 831, *Figure B-1*) to the 831-INT USB hub port (marked USB HUB INPUT, *FIGURE 2-4*).
 - Verify that the 831-INT USB Hub status light is on when the CBL159 USB cable is connected from the Model 831 to the 831-INT. If this light is not on:
 - ▶ Replace the USB Cable.
 - ▶ Ensure that the peripheral is enabled in the Model 831 settings and also that the settings are correctly set up for the specific peripheral. See various troubles with specific peripherals listed below.
 - If the Model 831 peripheral device still doesn't work then call customer support for further assistance.

My GPS001 GPS receiver does not work

Buildings, trees, and mountainous terrain can hinder GPS reception.

- Check all cable connections.
- Verify that the GPS receiver is enabled in the Model 831 System Properties.
- Try re-orienting the GPS receiver by moving it outside where it can be receive the GPS signal.
- If the light on the GPS receiver is not flashing then call customer support for further assistance.

My SEN031 weather station does not work

- Check that the CBL167 is plugged into the SEN031.
- Verify that the CBL167 cable is connected to 831-INT Logic I/O and Auxiliary Power; ensuring that power connections are correct (including polarity). *See Figure B-3.*

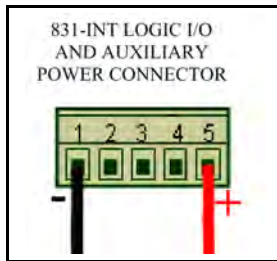

FIGURE B-3 PROPER POWER CONNECTIONS TO LOGIC I/O AND AUXILIARY POWER

- Ensure that the DVX008A (USB to Serial adapter) is plugged in correctly from the CBL167 to one of the 831-INT USB hubs (marked USB Port 1 through 4, *FIGURE 2-2 & FIGURE 2-4*).
- Verify that SEN031 is enabled in the Model 831 settings. See the Model 831 Technical Reference Manual for instructions.
- If the SEN031 weather station is still not working then call customer support for further assistance.

My MDMUSB-A analog modem does not work

- Check that the phone line is plugged in.
- Verify that a dial-tone is heard on both the phone line where the Model 831 and system is installed, as well as office location where the connection is being initiated. This can easily be tested with a standard telephone headset.
- Ensure that the modem is enabled and that all other modem settings are set up properly in the Model 831 settings and G4 LD Utility. See the Model 831 Technical Reference Manual for instructions.

- Make sure the modem password found in the Model 831 settings matches that being entered into G4 LD Utility.
- Check to see that the phone number is correct.
- Verify there is not a laptop connected directly to the Model 831 USB connector.
- If the MDMUSB-A is still not working then call customer support for further assistance.

My COM-RAVEN-DC Raven XE wireless Gateway does not work

- Ensure that your IT professional has set up and configured the Raven gateway for proper use, including setting up the gateway for cellular service with a data plan. Refer to the Raven XE users guide along with Larson Davis instructions specific to setting up for use with 831-INT-ET.
- Raven gateway POWER light does not come on when the Model 831 is on:
 - Ensure the Raven gateway is powered correctly with its own cable to the 831-INT-ET AUX POWER and Logic I/O port, with correct pins and polarities. *See Figure B-3.*
 - If Model 831 is powering up, but Raven gateway POWER light is still not coming on, call customer support for service and repair.
- The Raven gateway Ethernet green status light as well as the 831-INT-ET Ethernet port green status light should come on 3 minutes after the Model 831 powers up. If this does not happen:
 - Check Ethernet cable from 831-INT-ET to Raven gateway
 - Call customer support for service and repair.
- Raven gateway NETWORK light does not come on:
 - Verify that the SIM card is correctly installed and that the service is active.
 - Verify that the cell phone account is set up properly with a data plan and a static IP address

Note: Cell providers may provide good coverage for voice but poor coverage for data service. Therefore you cannot rely upon the bars of your cell phone to determine data coverage but should check with your service provider.

- Verify that the cellular service is available at the installed location.
- Verify that both antennas are installed on the Raven gateway.
- Raven gateway SIGNAL light (comes on after the NETWORK light comes on):
 - ▶ Solid: Very good cellular connection.
 - ▶ Blinking quickly: Good cellular connection.
 - ▶ Blinking slow: Poor cellular connection.
 - ▶ Off: No cellular connection.

- Verify that the IP address being used is correct when connecting with G4 LD Utility. The IP address will be provided by the cell service provider
- When working correctly, the network LED will be on and ideally the signal light will be solid. When the signal light is blinking slowly, expect sporadic and unreliable communication
- Contact cellular service and Larson Davis customer support for further assistance.
- Requirements for cellular service plan
 - Use a cellular service that can support data upload rates of 50 kbps or higher.
 - To avoid overage fees, verify that the type of cellular service data plan is adequate for the anticipated amount of data. See “Memory Utilization” in the Model 831 Technical Reference Manual.

My Model 831 is not showing any sound level signal from the Model 426A12

- Verify that both the CBL152 signal and CBL153 control cables are plugged in correctly to the Model 831, Model 426A12, and 831-INT. (*FIGURE 2-1.*)
- Ensure that the Preamp Type is listed as 426A12 on the Model 831.
- Ensure the microphone is correctly installed on the Model 426A12.
- Refer to the 426A12 Technical Reference Manual for further help.
- Call customer support for service and repair.

The IP Address on Model 831 is not shown.

- Verify that the Model 831 is properly assembled to 831-INT-ET, and both are turned on.
- Confirm connection of the Ethernet cable to 831-INT-ET and router, and the router is properly working. You can also connect the Ethernet cable to a PC.
- Reboot system. Check Tools > Communication on Model 831 display.
- If the DHCP is not found, the 831-INT-ET automatically sets the IP address 192.168.1.200 and this may not be shown on the screen. For this feature to work, the 831-INT-ET must have a firmware version V2.310 or newer, and the assembly needs to be rebooted.
- If connected directly into PC with Ethernet cable, you’ll need to set your PC IP Address to 192.168.1.###. Do not choose 200 for the last address, as this is the 831-INT-ET IP Address. See your network professional for further assistance.
- See "Connecting to Model 831 through 831-INT-ET using G4 LD Utility" on page 3-4 and use the IP Address 192.168.1.200

Miscellaneous Troubleshooting

- When connecting peripheral devices such as Raven or analog gateway, GPS receiver, or SEN031 weather station to the system, ensure that the Model 831 is turned off. Turn power on after peripherals are installed so that these devices will be properly recognized by the system.

